

DGP-M1 AND DGP-M1-V2

MODEL 1 TUNGSTEN GRINDER

(Formerly known as DGP-1)

USER MANUAL



"The Tungsten Electrode Experts"

since 1992

2651 Lavery Court • Newbury Park, CA 91320

Tel: 805.498.3837 • Fax: 805.498.9347

sales@diamondground.com

www.diamondground.com



DGP-M1 & DGP-M1-V2 MODEL 1 TUNGSTEN GRINDER

(Formerly known as DGP-1)

USER MANUAL

TABLE OF CONTENTS

General

General Description	3
Vacuum System Overview	3
Specifications	3
Unpacking	4
Warranty Information	4
Safety and Operating Guidelines	4
Maintenance	5
Mounting the DGP-M1	6

Using the Equipment

Electrode Grinding Assembly	6
The Basics	6
Operating Instructions	7
Recommended grinding times	8

Other Information

Exploded Views - Left & Right Sides	9,11
Parts Lists - Left & Right Sides	10,12
Accessories and Consumable Parts List	13



Models DGP-M1 and DGP-M1-V2

1. GENERAL DESCRIPTION

DGP-M1 Tungsten Welding Electrode Grinder is designed specifically for the longitudinal grinding of the conical or tapered points on tungsten welding electrodes from .040" (1.0mm) to 3/16" (4.8mm) in diameter. This model also offers a multi-purpose grinding wheel for other shop uses. The grinder is equipped with a completely enclosed ball bearing motor and a rotor and shaft assembly that is dynamically balanced for vibration-free rotation. The motor housing is compact and the unit has ample side clearance on the grinding and aluminum oxide wheels. Wheel guards are secured to the shaft by threaded nuts and safety eyeshields are also included.

DGP-M1 and DGP-M1-V2 Tungsten Electrode Grinders offer precise grinding for your precision welding needs. The DGP-M1 consists of a horizontal axis grinder that can be pedestal mounted, a diamond grinding wheel and assembly on the right side, and a general purpose aluminum oxide wheel for general shop uses on the left side. The DGP-M1-V2 adds a foam-insulated cabinet, vacuum system for dust collection, and a flexible spotlight in addition to the DGP-M1 features. The DGP-M1 can be upgraded later to a DGP-M1-V2.

The diamond grinding wheel on both grinders is on the right side of the machine and the surface rotates toward the electrode which provides consistent and repeatable points from each grind. The grinding surface faces right and the right wheel enclosure housing supports the electrode grinding assembly in addition to a Point Flat Dresser Block. The location of the area of contact between the diamond grinding wheel and the tungsten electrode is visible to the operator at all times, which allows for excellent control of the grinding operation. After repeated use, a groove will eventually be worn into the wheel at the contact point. The contact point should then be adjusted downward slightly to the next unused spot on the diamond grinding wheel. The grinding assembly on the left side also provides excellent visibility and is easy to operate for general grinding use, but is not recommended for tungsten because of the inferior finish it produces. Wheel rotation, viewed from the left end of the grinder, is clockwise.

VACUUM SYSTEM OVERVIEW

The DGP-M1-V2 comes with a tool cabinet and integrated vacuum system for the collection of tungsten dust. This feature has become very popular due to notifications in the past few years about the danger of inhaling dust from the commonly used 2% Thoriated tungsten, which is a known radioactive cancer-causing element. Please contact your local OSHA office if you would like more information about this issue. In addition, we offer free samples of non-radioactive alternative tungsten, which performs better in most applications. Users of the DGP-M1 can later upgrade their systems to add the vacuum system if chosen later.

It is impossible to contain all of the lightweight dust particles that deflect quickly off the wheels from grinding. The vacuum system offers a way of collecting the majority of the dust that is produced while grinding tungsten electrodes. Each side of the grinder has vacuum holes and hoses to collect dust. To maximize the suction power, use the valves at the back of the grinder motor to direct the suction to the side you are using. If you are using both sides at the same time, leave both sides open. However, if you are only using one side, close the valve on the opposite side and you will increase the suction power to the side you are using.

Replacement vacuum filters are in stock at the factory for immediate shipment.

2. SPECIFICATIONS

Motor: 1 HP 110/120 Volt, 60 Hz Standard OR 220/240 Volt, 50 Hz Optional

Wheels: **Right side:**
Nickel Plated Diamond Wheel, 6" diameter

Left side:
Aluminum Oxide Wheel, 6" diameter

Weight: DGP-M1: 42 lbs. / 19.05 kg in box
DGP-M1-V2: 152 lbs. / 68.9 kg on pallet

3. UNPACKING

Check for shipping damage. Diamond Ground Products takes great pride in producing quality equipment. If for some reason you find anything to be defective, please call us at: (805) 498-3837 and we will work with you to solve the problem. The following accessories are shipped with the DGP-M1 and DGP-M1-V2 grinders:

1. Pin Vise used to hold tungsten while grinding.
2. Six different Hex Keys, used to make various adjustments, and one Hex Screwdriver, used to secure the tungsten in the cutting apparatus.
3. Collets (four of your choice) - used to guide the tungsten and hold it at the proper angle while grinding.

4. WARRANTY

The DGP-M1 & DGP-M1-V2 comes with a one-year warranty on parts and labor, excluding wheels that are a consumable part that naturally wears over time. This warranty excludes abuse to the machine, dropping of the unit or improper handling by the operator.

5. SAFETY AND OPERATING GUIDELINES

Before any work is done, read the caution below carefully. Working safely prevents accidents.

- When not in use, turn the grinder off for safety purposes and to decrease wear on the machine.
- Wear proper apparel. Do not wear loose clothing, including gloves, neckties, rings, bracelets, or other jewelry, which may get caught, in moving parts of the machine.
- Wear protective hair covering to contain long hair.
- Wear safety glasses and a facemask.
- Never operate power tools when tired, intoxicated, or when taking medication that may cause drowsiness.
- Work area should have sufficient lighting.
- A proper electrical outlet should be available for the tools. A three-prong plug should be plugged directly into a three-prong outlet. Extension cord should be the correct gauge.
- Keep visitors at a safe distance from work area.
- Always unplug grinder prior to inspection.
- Read this manual thoroughly for specific adjustments and operating procedures.
- Do not perform “make-shift” repairs. Any part that is damaged should be promptly replaced.
- Only use the grinder for its intended purpose. Do not use it for a job it was not designed for.
- Make sure that the grinder is off before plugging it in.
- Do not apply extreme force on the tungsten while grinding. This may cause your grinder to jam or cause premature grinding wheel wear.
- Never leave the grinder unattended. Turn the grinder off first and do not leave it until it comes to a complete stop.
- Know your grinder; learn its operation, applications, and specific limitations.
- Always unplug grinder prior to inspection.
- Read this manual thoroughly for specific adjustments and operating procedures.
- Grinding parts other than tungsten will severely decrease wheel and equipment life.
- Unplug the grinder when changing accessories, such as collets, wheel, or other replacement parts.
- Avoid accidental start-up. Make sure that the grinder is in the off position before plugging it in.
- Do not force the grinder. It will work most efficiently at the rate for which it was designed. Consult the “Recommended Minimum Cutting and Grinding Time for New Electrodes” sticker on the grinder to determine optimum rate of speed.

Safety (continued)

- Use recommended accessories. Use of improper accessories may cause risk of injury of persons or accelerated wear on the grinder.
- Handle the tungsten and grinder correctly. Consult grinder operation procedures in this manual and handle tungsten with pin vise whenever possible to protect hands from possible injury.
- Feed tungsten into grinding wheel against the direction of rotation of the wheel.
- Turn the wheel off if it jams. A wheel jams when it digs too deeply into the tungsten (the motor force keeps it stuck in the tungsten).
- Never stand or lean on the grinder. Serious injury could occur if the grinder is tipped or if the cutting tool is unintentionally contacted.
- Keep hands away from moving parts and cutting surfaces.

Maintenance

- Always unplug grinder before inspection.
- Keep the grinder clean for safest operation
- Remove adjusting keys and wrenches. Form a habit of checking that keys and adjusting wrenches are removed before the grinder is turned on.
- Keep all safety guards in place and in good working order.
- Keep all parts in working order. Check to determine that the guard or other parts will operate properly and perform their intended functions.
- Check for damaged parts and alignment of moving parts, binding of moving parts, breakage of mounting parts and any other condition that may affect the grinders operation. Consult DGP factory for replacement parts at: (805) 498-3837
- Do not use power tools in dangerous environments, such as damp or wet locations. Do not expose power tools to rain.
- Work area should be properly lighted.
- The proper electrical outlet should be available for the tool. For 110V, a three prong plug should be plugged directly into a three prong outlet and /or extension cord.
- Keep visitors a safe distance from work area and keep children out of work place. Use padlocks or master switches to prevent any unintentional use of power tools.

SYMPTOMS	POSSIBLE CAUSES(S)	CORRECTIVE ACTION
Grinder won't start	1. Blown line or tripped circuit breaker	1. If fuse is blown, replace with fuse of proper size. If breaker is tripped, reset it.
	2. Low line voltage	2. If voltage is less than rated, check size of wiring from main switch on property. If OK, contact power company.
	3. Material wedged between wheel and guard	3. Remove material wedged between wheel and guard
Excessive vibration	1. Improper mounting of grinder or accessories	1. Remount
	2. Improper wheel mounting	2. Remove both wheels then remount wheels but rotate one wheel 1/4 turn with respect to its previous position. The other wheel would retain its original position.
Grooved wheel	1. Electrode pushed with excessive force	1. Use recommended grinding times table
	2. On steep angled tungsten, collet touching wheel	2. Use short collets available from Diamond Ground Products
Motor is overheating	1. Motor not turning freely (without power)	1. Clean around wheels & shaft. Then replace bearings

Mounting the DGP-M1

The DGP-M1 stand alone grinder (without vacuum system and cabinet) should be mounted to a solid horizontal surface (mounting hardware is not provided).

If mounted to a metal cabinet or pedestal, align the mounting holes with the corresponding holes in the cabinet or pedestal. Insert a 1/4"-20 X 1 1/4" hex head bolt with flat washer beneath the head of the grinder. From the bottom of the cabinet or pedestal, place a 1/4" flat washer and 1/4"-20 hex nut onto the bolt extension. Tighten only until the space between the grinder base and the cabinet or pedestal is 1/8". Using a second nut on each bolt, tighten against the first to prevent loosening by vibration.

If mounted to a wooden bench top, use 1/4" wood screws that are 1-1/4" long with flat washer beneath the heads. Tighten screws until the space between the grinder base and the bench is 1/8".

Electrode Grinding Assembly

The Basics

The Electrode Grinding Assembly is attached to the right wheel housing (refer to Figure 1 for the general arrangement of the assembly). It provides the means to support an electrode in a fixed position relative to the diamond-grinding surface through an electrode guide collet that matches the electrode diameter. The electrode is brought into gentle contact with the diamond-grinding surface and at the same time is rotated slowly in one direction between the operator's thumb and forefinger. As an alternative, pin vises are also provided to hold the tungsten during rotation. Note: all positioning and adjustment should be made before turning on the grinder.

Operation Instructions

Please refer to Figure 1 below for the optimum location of the electrode point contact area with respect to the grinding surface. In the position shown, the motion of the diamond grinding wheel surface is parallel to the centerline of the electrode to accomplish longitudinal grinding of the electrode point. When grinding very steep angles, such as 10°, be careful that the electrode guide collet does not make contact with the diamond grinding wheel. This can contaminate the wheel and reduce the life of the wheel significantly. For these types of angles, you may need to consult the factory to obtain optional short collets that are available for these applications.

Refer to Figure 2 below for use with the following operation instructions:

1. If the tungsten you are using is already flat at the end, like new tungsten straight out of the box, proceed to Step 4.
2. Locate the Point Flat Dresser Block (DGP-PG1477) attached at the 6 o'clock position of the right side wheel cover. Find the hole that matches the diameter of your tungsten and turn on the grinder. Slowly push the tip against the wheel until the point is removed. Once again, be patient and do not gouge the wheel. A burr can form if too much pressure is exerted on the tungsten.
3. Select the electrode guide collet with the hole diameter closest to the tungsten electrode diameter and position it in the electrode guide collet tube. Notice that the collet has been beveled on a 15° angle at the front or exit end of the collet. With this surface parallel to the grinding wheel surface, tighten the set screw to hold it in place. The back, or entrance, end of this collet has been milled down to its center line to make it easy to insert the electrode for grinding.
4. Adjust the angular position of the electrode grinder assembly to the desired included angle of grind for the electrode point using the angle adjustment handle (Handle A).

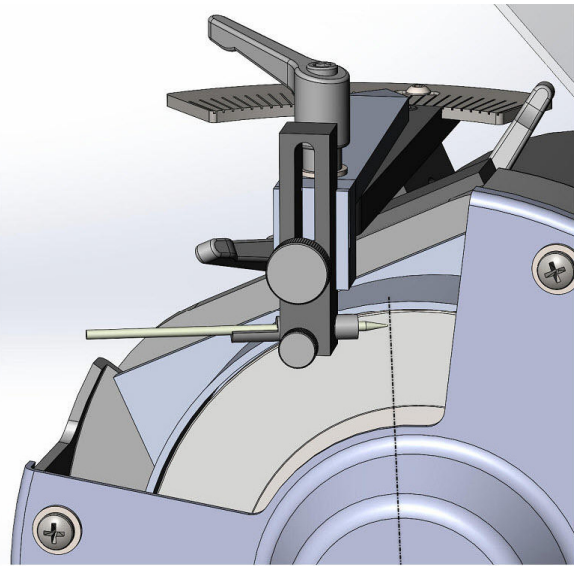

Figure 1: Optimal location of electrode point contact area

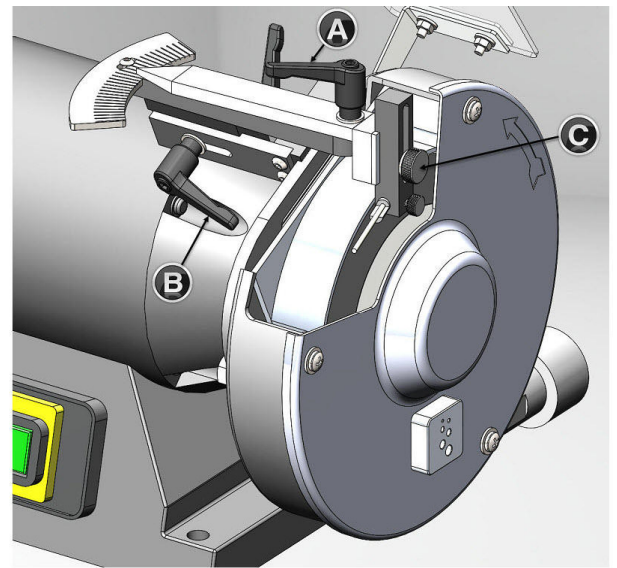

Figure 2: Electrode grinding assembly

Electrode Grinding Assembly Cont'd

5. Left to right positioning: Adjust the position of the electrode grinder assembly using the horizontal adjustment knob (Handle B) to place beveled surface of the electrode guide collet approximately 1/64" from the grinding surface.
6. Slip a tungsten electrode into and through the electrode guide collet to determine where it will contact the grinding disk surface.
7. Up and down positioning: Adjust the electrode grinder assembly using the vertical adjustment knob (Knob C) so that the tungsten electrode will contact the actual grinding surface.
8. Remove the tungsten electrode from the electrode guide collet.
9. Put the eyeshield in place and start the grinder. Slide the tungsten electrode into and through the electrode guide collet and twirl the electrode (or the pin vise holding the electrode) slowly in one direction between thumb and forefinger as it approaches and makes contact with the grinding surface. To retain maximum symmetry of the point, try to keep from moving the electrode side to side within the collet. The best technique for this is to constantly lean the electrode against the inside surface of the collet while turning. Continue grinding until the desired sharpness is obtained. Make sure to continue rotation as the electrode is backed off from the wheel or a flat spot may occur along the point. Contamination of the wheels can occur by using the diamond grinding and cutting wheels as all-purpose shop wheels. If you grind tools or other metal items, other than electrodes, there is always the risk of contaminating the wheels.

In addition to proper positioning and avoiding contamination, use the recommended grinding times in Table 1 below to increase the longevity of the diamond grinding wheels. The wheel can be used with very limited wear by working according to these guidelines. Wear of the wheel will double if the grinding time is reduced by one half using more applied force and wear will triple if the time is reduced by one third. Be patient and do not gouge the wheel!

For users requiring extreme tolerances, a laser cut tip/flat gauge is available from Diamond Ground Products to accurately measure tip diameter. See page 13 for the part number. Also note, a microscope or comparator can be used to verify the angle (taper) of the grind in a very precise and efficient manner.

Electrode Diameter (In.)	Electrode Diameter (mm)	Grinding Time
.040"	1.0mm	5-8 sec
1/16"	1.6mm	11-15 sec
3/32"	2.4mm	15-20 sec
1/8"	3.2mm	25-35 sec
5/32"	4.0mm	30-40 sec
3/16"	4.8mm	55-65 sec

Table 1: Recommended grinding times for each diameter.

Consult Illustrated Parts Lists on the following pages
and
See Page 13 for optional Accessories and Consumables Parts List

DGP-M1 PRECISION TUNGSTEN GRINDER LEFT SIDE

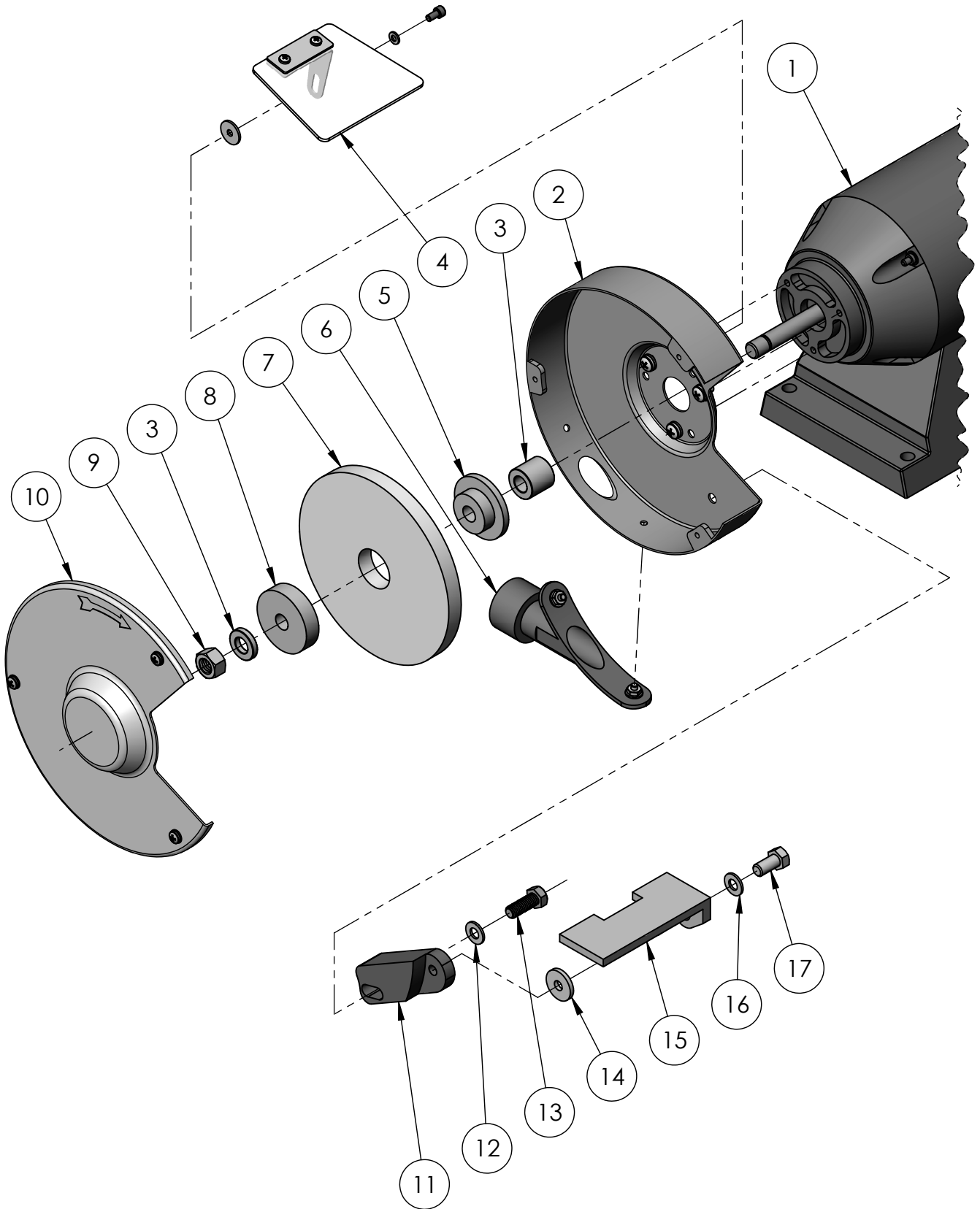

DGP-M1 PRECISION TUNGSTEN GRINDER LEFT SIDE

ITEM	PART NUMBER	DESCRIPTION	QTY
1	DGP-P400-A DGP-P400-B	BENCH GRINDER-MOTOR 7" 1HP 120V - STANDARD BENCH GRINDER-MOTOR 7" 1 HP 220V – OPTIONAL	1
2	DGP-F280-A	INSIDE WHEEL COVER W/HARDWARE	1
3	DGP-P671-A	ARBOR SPACER W/WASHER	1
4	DGP-P663-L	EYESHIELD – PLEXIGLASS W/HARDWARE	1
5	DGP-F160	HUB – INNER	1
6	DGP-P602	WHEEL GUARD W/HARDWARE	1
7	DGP-P770	MULTI PURPOSE WHITE ALUMINUM OXIDE 6" WHEEL, 80 GRIT	1
8	DGP-F170	HUB – OUTER	1
9	DGP-F233	NUT – HEX ½" – 12 LH THREAD	1
10	DGP-F279	OUTSIDE WHEEL COVER W/HARDWARE	1
11	DGP-F050-A	SUPPORT ARM	1
12	DGP-P733	WASHER – LOCK 5/16"	1
13	DGP-P603	BOLT – HEX SOCKET HEAD 5/16"	1
14	DGP-P604	WASHER – FLAT 5/16" X 1/8" - STEEL	1
15	DGP-F030	BASE – ELECTRODE CUT OFF	1
16	DGP-P725	WASHER – FLAT 3/8"	1
17	DGP-P310	SCREW - BOLT HEX SOCKET HEAD 3/8" - 1/16 x 1"	1

DGP-M1 PRECISION TUNGSTEN GRINDER RIGHT SIDE

ITEM	PART NUMBER	DESCRIPTION	QTY
1	DGP-P400-A DGP-P400-B	BENCH GRINDER-MOTOR 7" 1HP 120V - STANDARD BENCH GRINDER-MOTOR 7" 1 HP 220V - OPTIONAL	1
2	DGP-P605-A DGP-P609-A	ON-OFF SWITCH (STANDARD) 110V ON-OFF SWITCH (OPTIONAL) 220V	1
3	DGP-F277-A	RIGHT WHEEL INSIDE COVER W/HARDWARE	1
4	DGP-P602-A	WHEEL GUARD W/HARDWARE	1
5	DGP-P673-A	ARBOR SPACER W/WASHER	1
6	DGP-PG1439	SCREW – SHSS ¼”- 20 x 3/8” CUP PT BLK	1
7	DGP-F155-A	ARBOR	1
8	DGP-PG1425 DGP-PG1426	WHEEL – DIAMOND 300 GRIT (STANDARD) WHEEL – DIAMOND 600 GRIT (OPTIONAL)	1
9	DGP-PG1442	SCREW – BHSCS #10-32 x ½” BLK	4
10	DGP-PG1349	SCREW – BHSCS #6-32 x ¼” BLK	4
11	DGP-F278-A	RIGHT WHEEL OUTSIDE COVER W/HARDWARE	1
12	DGP-PG1477	BLOCK - FLATTING	1
13	DGP-F231	NUT – ½” 12 HEX-RH THREAD	1
14	DGP-P660	SCREW – BHSCS #10-32 x 1 ¼” BLK	2
15	DGP-P730	WASHER – BLK FLAT #10 x ½” OD x 3/32” THK	5
16	DGP-F220-A	INSIDE DUST SHIELD	1
17	DGP-PG1458	PLUG FINISHING ½” SNAP BLK	1
18	DGP-P672	SCREW – SHC #10-32 x 5/8” BLK	1
19	DGP-F230-A	SUPPORT BRACKET	1
20	DGP-P725	WASHER - FLAT 3/8”	1
21	DGP-P310	BOLT – HEX HEAD 3/8” 16 x 1	1
22	DGP-F255-A	Y AXIS CLAMP BLOCK	1
23	DGP-P660	SCREW – BHSCS #10-32 x 1 ¼” BLK	2
24	DGP-P661	SCREW – BHSCS #10-32 x 1 BLK	2
25	DGP-F049 DGP-F060 DGP-F070 DGP-F080 DGP-F090 DGP-F100 DGP-F110	COLLET - .020” COLLET - .040” COLLET – 1/16” COLLET – 3/32” COLLET – 1/8” COLLET – 5/32” ID ¼” OD COLLET – 3/16”	CHOICE OF 4 TOTAL
26	DGP-P440	KNOB - #6 BLK	1
27	DGP-PG1320	SCREW – BHSCS #6-32 x 3/8” BLK	1
28	DGP-P460	KNOB - #10 BLK	1
29	DGP-PG1363	SCREW – SHCS #10-32 x 1” BLK	1
30	DGP-F260	Z AXIS CLAMP BLOCK	1
31	DGP-F007-A	ANGLE POINTER	1
32	DGP-P730	WASHER – FLAT #10 x ½” OD x 3/32”	4
33	DGP-P410	HANDLE – ADJUSTABLE THREADED HOLE - BLK	3
34	DGP-P541	SCREW – BHSCS #6-32 x 3/8” BLK	1
35	DGP-F025-A	ANGLE SCALE – RT HAND	1
36	DGP-P571	SCREW – BHC #8-32 x ½” BLK	2
37	DGP-F225-A	SCALE SUPPORT BAR	1
38	DGP-F242-A	X AXIS CLAMP BLOCK	1
39	DGP-F245-A	X AXIS GUIDE BAR	1
40	DGP-P542	SCREW – BHSCS #8-32 x ½” BLK	2
41	DGP-P177	BOLT – HEX 3/8” 16 x ¾” ZINC	1
42	DGP-P604	WASHER – FLAT 5/16” x 1/8” - STEEL	1
43	DGP-P733	WASHER – LOCK 5/16”	1
44	DGP-P663-R	EYE SHIELD – PLEXIGLASS W/HARDWARE	1

ACCESSORIES AND CONSUMABLES PARTS LIST

Description		Part no.
300 Grit Grinding Wheel - For grinding .040" to 3/32" (1.0mm to 2.4mm)		DGP-PG1425
600 Grit Grinding Wheel - For grinding 3/32" to 3/16" (2.4mm to 4.8mm)		DGP-PG1426
Aluminum Oxide Wheel		DGP-P770
Vacuum Filters (Cartridge type for vacuum units only)		DGP-M968
Upgrade to Vacuum System (Includes cabinet, vacuum system and flexible spotlight)		DGP-UPG
Flexible Spotlight (No bulb)		DGP-P490
Replacement Bulb for Flexible Spotlight (110V / 220V version)		DGP-P480
Tip/Flat Gauge (For measuring the diameter of the tip/flat)		DGP-F145
Replacement Collets	.040" (1.0mm)	DGP-F060
	1/16" (1.6mm)	DGP-F070
	3/32" (2.4mm)	DGP-F080
	1/8" (3.2mm)	DGP-F090
	5/32" (4.0mm)	DGP-F100
	3/16" (4.8mm)	DGP-F110
Cabinet Only (no vacuum or flexible spotlight)		DGP-P685
Replacement Grinder Switch	110 V (Standard)	DGP-P605-A
	220 V (Optional)	DGP-P609-A
Pin Vises	Small .040"-1/16" (1.0mm to 1.6mm)	DGP-P513
	Medium 1/16" to 1/8" (1.6mm to 3.2mm)	DGP-P514
	Large 1/8" to 3/16" (3.2mm to 4.8mm)	DGP-P515

To order your replacement parts, or if we may assist you, please call us:



2651 Lavery Court • Newbury Park, CA 91320
 Tel: 805.498.3837 • Fax: 805.498.9347
 sales@diamondground.com
 www.diamondground.com

